



AZKOYEN
GROUP



USER MANUAL

VITRO "X-1" ESPRESSO



AZKOYEN S.A.

Av. San Silvestre S/N
31350 PERALTA
Navarra, ESPAÑA

Azkoyen Andina S.A.S.

Vía Virginia
Corregimiento Caimalito, Bodega B-16
Zona Franca Internacional
660007 – Pereira, COLOMBIA



WARNINGS.....	5
UE Declaration of Conformity.....	8
CHAPTER 1. GENERAL CHARACTERISTICS.....	9
1.1.- Description of the VITRO X1 line.	9
1.2.- Description of the main components	10
CHAPTER 2. INSTALLATION AND START-UP	11
2.1.- Choosing a machine location	11
2.2.- Dimensions required for mounting the machine on a countertop.....	11
2.3.- Electrical installation	11
2.4.- Water supply.....	12
2.5.- Changing the product sign	12
2.6.- Start-up.....	12
2.7.- First cleaning.....	13
2.8.- Payment module.....	13
CHAPTER 3. DESCRIPTION OF THE MACHINE	15
3.1.- Soluble product hoppers.....	15
3.2.- Initial loading of soluble product	15
3.3.- Loading coffee beans	15
3.4.- Initial loading of water	15
3.5.- Independent water tap	15
3.6.- Bean coffee group (Espresso Machines)	16
3.7.- Installing personalised side panels.....	17
CHAPTER 4. CONFIGURATION AND PROGRAMMING.....	19
4.1.- What is programming?.....	19
4.2.- Programming control unit.....	19
4.3.- Direct access to a function.	20
4.4.- List of functions.....	20
4.5.- Service programming.	21
CHAPTER 5. ANOMALY CONTROL AND MAINTENANCE	25
5.1.- Reset	25
5.2.- Possible incidents during a service.....	25
5.3.- Service Meters	25
5.4.- Disassembly of the coffee bean unit	26
5.5.- Adjustments and regulation.....	26
5.6.- Programming the water temperature under special conditions	28
CHAPTER 6. CLEANING THE MACHINE	29
6.1.- Components that require regular cleaning	29
6.2.- Regular cleaning of the machine and maintenance operations	31
6.3.- Cleaning cycle for the group brewing chamber.....	31
6.4.- Exterior cleaning	33
Anexe 1. THE TREATMENT, COLLECTION, RECYCLING AND DISPOSAL OF THIS DEVICE.....	34





WARNINGS

General

- **BEFORE USING THIS DISPENSER, THIS MANUAL MUST BE READ CAREFULLY**
- This automatic dispenser has been designed and built in accordance with all safety legislation in force.

Installation

- **THE INSTALLATION AND OPERATIONS REQUIRED FOR INITIAL START-UP OF THESE MACHINES MUST BE PERFORMED BY QUALIFIED PERSONNEL. THE SERVICE AREA MUST ONLY BE ACCESSED BY QUALIFIED TECHNICAL STAFF WITH EXPERIENCE IN HANDLING THIS MACHINE, IN PARTICULAR, AS REGARDS HEALTH AND SAFETY.**
- **THE MACHINE MUST BE PLACED ON A PIECE OF FURNITURE OR SUPPORT, SO IT IS STABLE AND CANNOT BE TIPPED OVER BY ACCIDENT.**
- You might need to access the inside of the machine from the rear; please choose a place from which you can turn the machine around to open the rear door and to perform the maintenance and cleaning tasks while this door is open. Try not to remove the machine's anchoring elements; in case these need to be removed, remember to fit them back on after you complete all tasks.
- The plug of the machine has an earth connection. The outlet must be connected to a good earth connection and must be located in an accessible position once the machine is installed.
- These machines are designed **EXCLUSIVELY FOR INDOOR USE**. They must not be installed in places that may be exposed to sprayed water, and they likewise must not be cleaned using sprayed water.
- Ensure that the electrical installation, the outlet and the automatic circuit breaker have the appropriate sizes for machine consumption.
- **AZKOYEN** hereby declines all liability for damages caused to persons or things as a result of the following:
 - Incorrect installation.
 - Inadequate electrical and/or hydraulic installation.
 - Deficient cleaning or maintenance.
 - Incorrect use of the machine.
 - Using non-original replacement parts or making unauthorised modifications
- If it is necessary to move the machine avoid:
 - Tipping the machine
 - Dragging or lifting it with some kind of pulling system (rope, straps, etc.).
 - Shaking or striking the machine, no matter whether it is in protective wrapping or not.



Safety

- **ALL ELEMENTS THAT REQUIRE TOOLS TO BE DISASSEMBLED MUST ONLY BE HANDLED BY QUALIFIED TECHNICAL PERSONNEL.**
- The machine should be installed in locations that meet the recommendations of temperature, electrical and water installations, weights, etc., in this manual and performed by qualified personnel.
- **THE MACHINE HAS COMPONENTS THAT OPERATE AT DANGEROUS VOLTAGES. DO NOT DISCONNECT ANY COMPONENT. ONLY TECHNICAL SERVICE IS AUTHORISED. THE FEEDER CABLE CAN ONLY BE REPLACED BY AUTHORISED TECHNICAL PERSONNEL.**
- This appliance is not designed to be used by persons (including children) with reduced physical, sensory or mental capabilities, lack of experience or knowledge, unless they are supervised or have been instructed in its use by somebody responsible for their safety. Children should be supervised to ensure that they do not play with the appliance. Section 7.12 of EN60335.
- This appliance is not designed to be used by persons (including children aged 8 and above) with reduced physical, sensory or mental capabilities, lack of experience or knowledge, unless they are supervised or have been instructed in its use by somebody responsible for their safety.
- In any case, this appliance cannot be cleaned and serviced by unsupervised children.
- **AZKOYEN** guarantees that all elements in contact with water or foodstuffs meet the legal requirements established in regulation (EC) 1935/2004, or subsequent updates, in relation to materials and objects that come into contact with foodstuffs.



Maintenance

- **MAINTENANCE AND CLEANING TASKS MUST ONLY BE CARRIED OUT BY QUALIFIED STAFF WHO HAVE BEEN TRAINED ON USE AND MAINTENANCE OF THIS MACHINE. ALL OPERATIONS MUST BE CARRIED OUT WITH THE MACHINE DISCONNECTED FROM THE MAINS.**
- For refilling, only use food products prepared specifically for these kinds of vending machines. Do not touch the product with your hands, and prevent liquids from falling inside the product hoppers.
- Given the characteristics of some food products, these may lead to incorrect operation of the machine if used beyond the parameters of temperature and relative humidity recommended in this manual.
- Water must be prevented from freezing in the interior of the machine. If any maintenance task is going to be performed and the machine is going to be disconnected for a long period of time, the boiler must be emptied.
- **IF THE MACHINE IS NOT GOING TO BE USED AND WITHOUT SUPERVISION DURING A PERIOD OF TIME, WE RECOMMEND CLOSING THE WATER TAP CONNECTED TO THE MACHINE. MALFUNCTION OF THE INPUT VALVE COULD FLOOD THE MACHINE**



Cleaning tips

- The user or person responsible for refilling and cleaning the device must follow the instructions set forth in this manual.
- **These machines operate with water at high temperatures and steam and hot water might be released during the cleaning procedures. Keep your hands far from the liquid outlets. Hot liquids could cause irritation, burns or scalding on your skin.**
- Machines with the fresh milk mechanism must be cleaned every day, removing all milk and coffee remains. Otherwise, harmful bacteria could appear. Provide a clear explanation of the cleaning process to the person responsible for cleaning the machine every day.
- The elements used in the fresh milk cleaning service must be handled and cleaned according to the corresponding legal requirements related to food safety and hygiene.
- Only use the products recommended by the machine's manufacturer. Use of generic products not only does not guarantee that the machine can be cleaned properly, but may alter the taste of some drinks or result in situations that are harmful to health.



User manual

- This manual is an integral part of the machine, and as such, it must always remain inside the same so that it may be consulted at any time.
- This document contains private property information protected by legislation on intellectual property. All rights are hereby reserved. No part of this document may be photocopied, reproduced or translated without the prior written consent of AZKOYEN.
- AZKOYEN hereby reserves the right to introduce, without prior notice, all improvements to this model derived from its constant research.
- **REMEMBER: To get the most out of your machine, follow the instructions in this manual.**
- **FOR ANY ADDITIONAL INFORMATION THAT IS NOT SPECIFIED HEREIN CONTACT YOUR DISTRIBUTOR OR ACCESS THE TECHNICAL MANUAL FROM AZKOYEN'S OFFICIAL WEBPAGE**



UE Declaration of Conformity



We, the manufacturer, Azkoyen Vending Systems, declare under our sole responsibility that our product is in compliance with the essential requirements of the following European Union issued Directives:

- EMC Directive 2014/30/UE, and his modifications
- Machine directive 2006/42/EC
- Low Voltage Directive 2014/35/UE
- RoHS Directive 2011/65/UE, and its amends Directive 2015/863/UE
- Regulation 1935/2004, on materials and articles intended to come into contact with food.
- Regulation (EC) Plastic materials and items to be used in contact with foodstuffs 10/2011
- Regulation (EC) Best manufacturing practices for materials and items to be used in contact with foodstuffs 2023/2006

The product is according with the following norms / standards:

- IEC 60335-1:2010/AMD2:2016/COR1:2016
- IEC 60335-2-75:2012/AMD2:2018
- UNE-EN 55014-2:2015 (EN 55014-2:2015; CISPR 14-2:2015)
- UNE-EN 55014-1:2017 (EN 55014-1:2017, CISPR 14-1:2016/COR1:2016)
- UNE-EN IEC 61000-3-2:2019 (EN IEC 61000-3-2:2019; IEC 61000-3-2:2018)
- UNE-EN 61000-3-3:2013/A1:2020 (EN 61000-3-3:2013/A1:2019; IEC 61000-3-3:2013/A1:2017)

Azkoyen Vending Systems

AUda. San Silvestre, s/n
31350 – peralta. SPAIN



CHAPTER 1. GENERAL CHARACTERISTICS

1.1.- Description of the VITRO X1 line.

The machines on the VITRO X1 range are TABLETOP coffee and soluble beverage machines especially designed for use in areas with medium coffee consumption, such as waiting rooms, medium-sized offices, etc.

The machine features two built-in soluble product containers and a coffee bean group.



Products and serving selection system	
No. bean containers	1
No. soluble product containers	2
Bean container capacity (l.)	1,1 l
Capacity per soluble product hopper	3 l
Number of selections	12
Dimensions (mm)	
Depth	670
Height / Height with stand	305
Width	500
Weight (kg)	26,2
Electrical specifications	
Voltage	according to the characteristics plate (+6V/-10V)
Maximum consumption	1.500W
Characteristics of the water supply system	
Types of water service connections	Water supply system
Min. pressure of the water supply system	min 0,049 Mpa.; Max. 0,98 Mpa
Curb cock diameter	¾" M
Other characteristics	
Maximum working inclination	2º (on any axis)
Sound level	<80 dB(A)
Optimum exterior temper. Environment	1ºC < T > 40ºC; <65% Rel. hum.



1.2.- Description of the main components

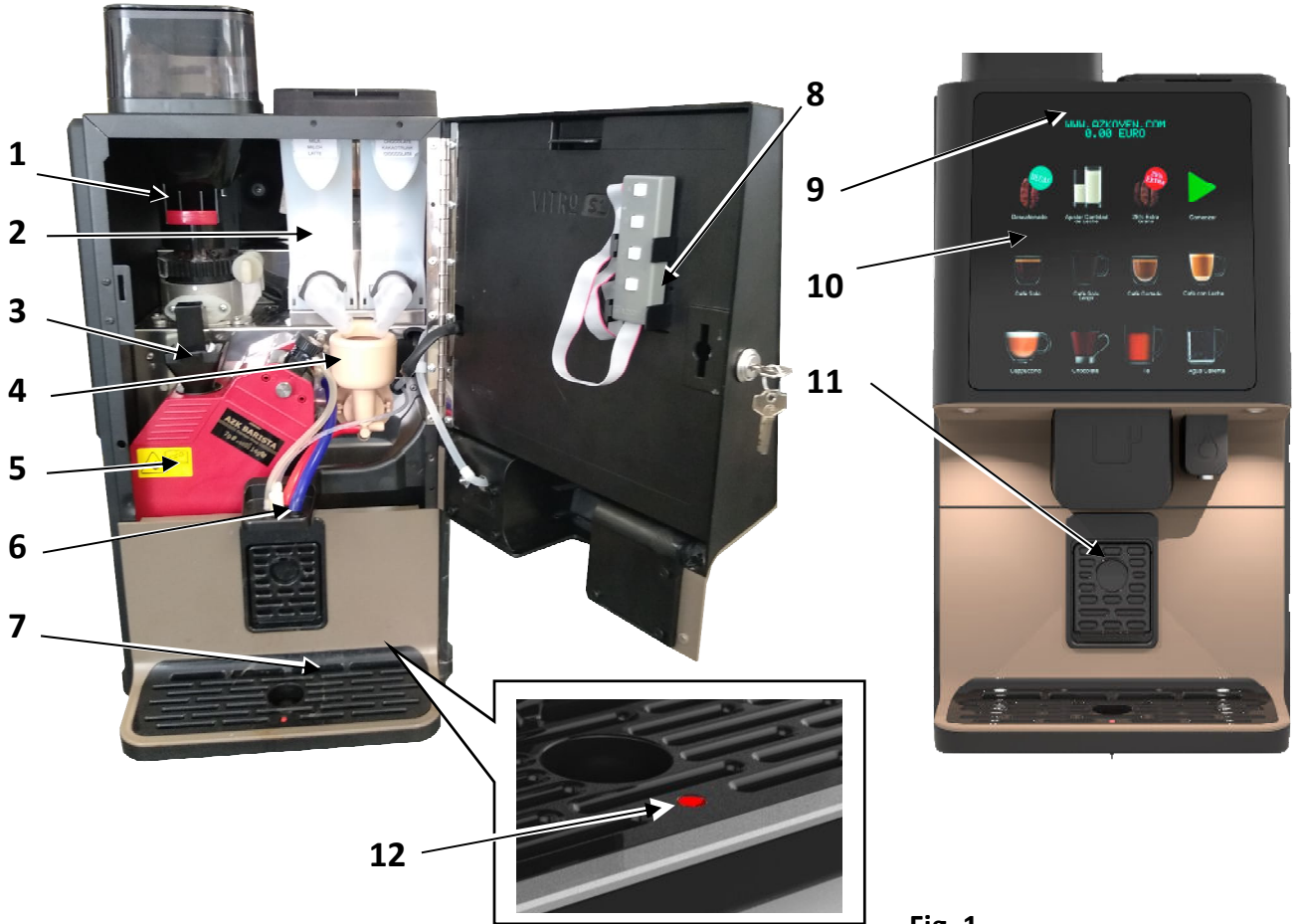
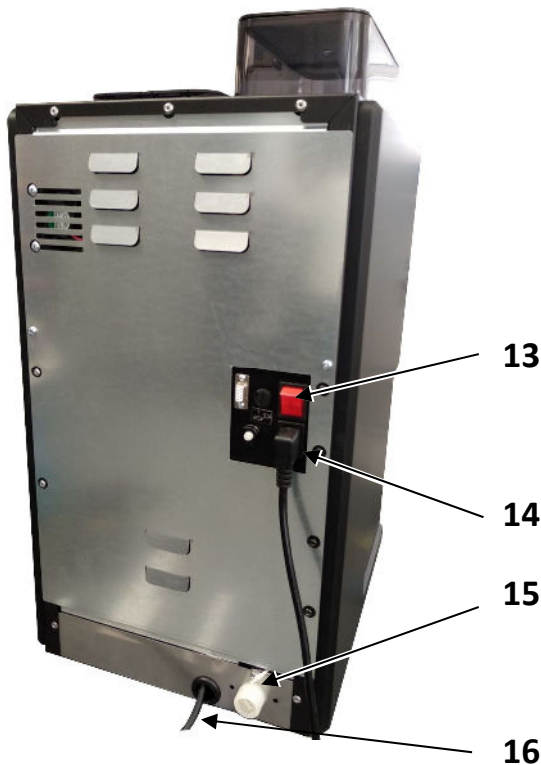

Fig. 1

1. Coffee bean container
2. Soluble product container
3. Ground coffee doser
4. Soluble product blender
5. Coffee bean group
6. Rubber threshold
7. Drip tray
8. Programming control
9. Display
10. Selection buttons
11. Cup holder
12. Tray full level
13. On/Off switch
14. Connection cable
15. Network water tap
16. Supply bundle of the fresh milk module (optional)





CHAPTER 2. INSTALLATION AND START-UP



THE INSTALLATION AND OPERATIONS REQUIRED FOR INITIAL START-UP OF THESE MACHINES MUST BE PERFORMED BY QUALIFIED PERSONNEL.

2.1.- Choosing a machine location

THE MACHINE MUST BE PLACED ON A PIECE OF FURNITURE OR SUPPORT, SO IT IS STABLE AND CANNOT BE TIPPED OVER BY ACCIDENT. THE SUPPORT MUST BE WELL SECURED TO THE WALL.

Before choosing the location for your “VITRO X1” machine, keep in mind that if any aintenance or repair work has to be performed, it is possible that the interior of the machine may have to be accessed from the rear. A place must be selected where it is possible to eventually turn the machine around in order to be able to open the rear.

The machine has the elements required to store waste internally (Fig. 1). These elements have been designed for a machine with a medium-low service level that is cleaned on a daily basis.

If these elements are insufficient due to the number of services of the machine, waste may be stored outside the machine.

You can place the machine on a countertop and adjust it to ensure that the waste passes through the machine and falls into a container under the countertop.

2.2.- Dimensions required for mounting the machine on a countertop

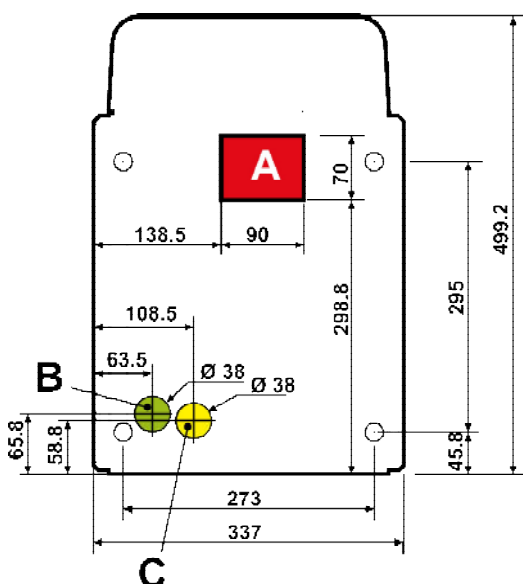

Take into account the following dimensions before adapting the countertop to mount the machine:

- A. Coffee bean waste outlet
- B. Liquid drain tray
- C. Tube entry from lower tank and sensor cables.

These openings are pre-cut in your machine; use a suitable tool to cut the plate and open them.

2.3.- Electrical installation

The voltage of the electrical system must comply with the voltage indicated on the characteristics plate on the back of the machine and must not exceed the limits set in the country of use.

Maximum power consumption is indicated on the machine characteristics plate.



2.4.- Water supply

If your machine is fitted with mains service, then prepare a water supply where the machine is to be fitted in accordance with the indications in the general characteristics table. The distance between this water supply and any electric socket base must be at least 1 m. Observe European directives.

2.5.- Changing the product sign

Disconnect the machine and remove the plastic nut that fastens the top of the buttons.

Pull back the cover to remove the selections menu. Press the upper tab and pull from it outward to extract the selection card.

Remove the desired labels by pressing against them from the top of the label holder. Insert the new labels through the label holder guides.

Once the necessary operations have been made, restore the cover and the cups container back to their correct position.

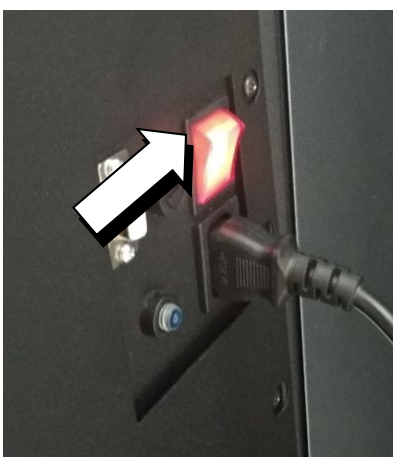
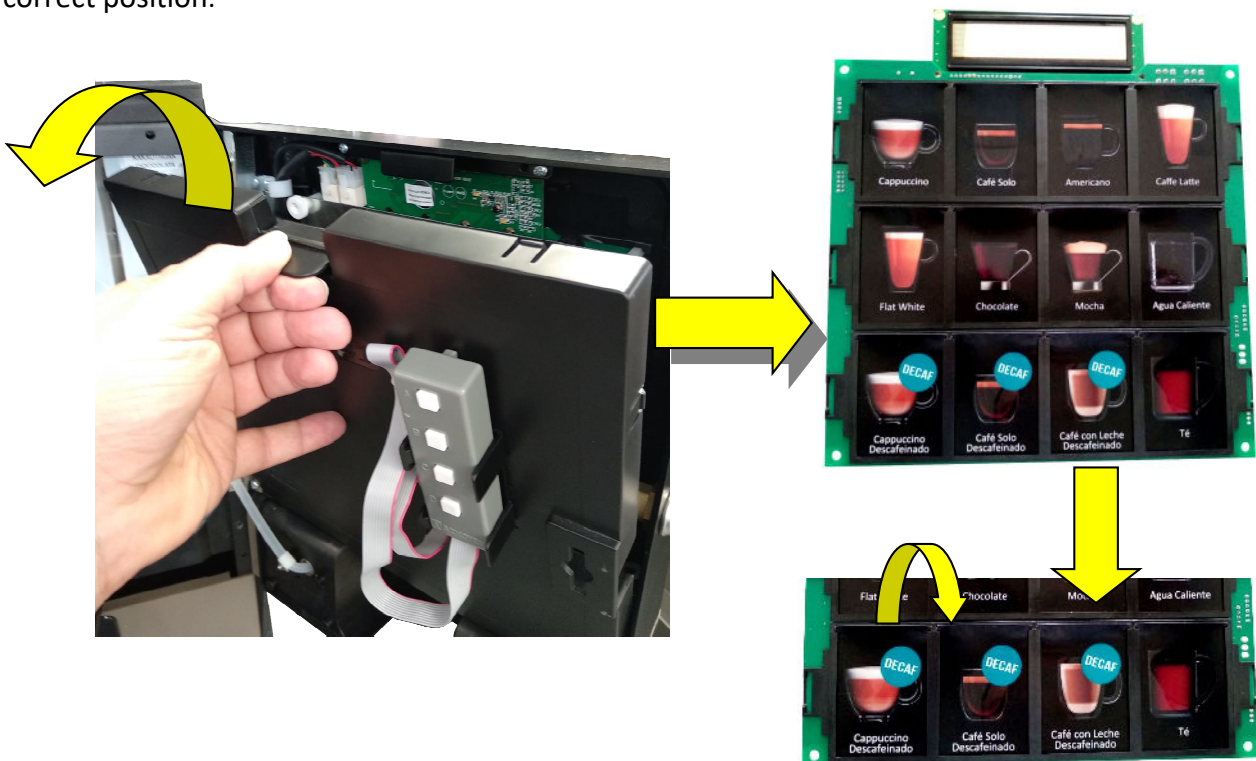

2.6.- Start-up

Once the tank has been filled or the water hose has been connected to the mains and current fed to the socket, close the door: The machine will be ready for use in a few minutes.

Press the switch on the back of the machine.



2.7.- First cleaning

The system must be cleaned the first time the machine is switched on:

- Remove the mixers and clean with hot water
- Remove the product hoppers and wash with hot water
- Clean the hopper base
- Mount everything back on again
- Wash the mixers at least 5 times by pressing key B on the programming control.

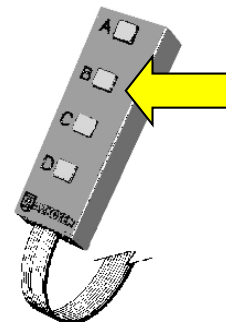

If the machine has not been used for a period of time, we recommend washing it with this process again before you start it up.

2.8.- Payment module

The machine can feature an optional payment module, which supports connection of a validator with MDB protocol. The installation instructions are included in the corresponding kit.

THE MACHINE CAN ONLY BE POWERED WITH 24DC (NOT WITH 24VAC).





CHAPTER 3. DESCRIPTION OF THE MACHINE

3.1.- Soluble product hoppers

The Instant and Espresso+2 machines have 2 or more soluble product containers.

These containers extract the product via a spindle to the Blender, where it is mixed with water sent from the boiler.

Each hopper must always be loaded with the same type of product because the serving configuration activates the hopper programmed for each case.

E.g. do not load the MLK hopper with a different product because the machine will use it for servings programmed with MILK.



3.2.- Initial loading of soluble product

Lift the lid of the hopper to be loaded and load the product. Be careful that the product filled corresponds to product for that hopper (each hopper has a label that indicates the product to be filled).

Recommendation: The ramp on which the product falls from the hopper should be turned upwards to prevent unwanted product spillage.

Once the product has been filled, close the hopper cover and proceed to fill the next hopper.

3.3.- Loading coffee beans

Lift the hopper lid and pour in the contents of the packet of coffee to the desired level.

3.4.- Initial loading of water

All the machines automatically fill the boiler when the machine is started up.

3.5.- Independent water tap

VITRO X1 features an independent hot water tap used for tea and other infusions.

This water tap receives the programmed water dose directly from the boiler, without passing through a beater, allowing the machine to operate at higher temperatures.





3.6.- Bean coffee group (Espresso Machines)

The coffee beans are stored in the grinder hopper. When a serving is requested, the brewing group moves to the loading position and the grinder grinds the amount of coffee programmed, sending it to the doser, where the coffee is dosed and then falls to the brewing piston.

The group then advances to the brewing position and the piston tamps the coffee.

The pump injects the programmed water into the group for the pre-set length of time. The result of this operation is the Espresso coffee which pours into the cup.

Fig. 2

- 1 Hopper
- 2 Doser
- 3 Upper piston
- 4 Lower group
- 5 Group anchoring lever
- 6 Grinder adjustment lever
- 7 Coffee outlet tube
- 8 Group positioning crank

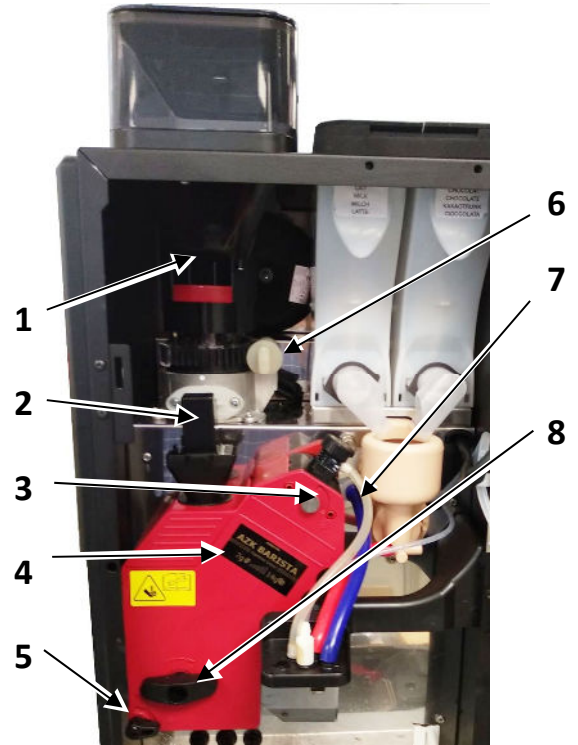

There are three coffee bean groups, according to their adjustment capacity:

- **AZK V10** -> brews coffee, preparing doses from 5 to 8 g of coffee, with manual adjustment, if the grinder features a timed dosing system.
- **AZK V20** -> brews coffee, preparing doses from 10 to 14 g of coffee, with manual adjustment, according to the programmed services.
- **AZK V30** -> brews coffee, preparing doses from 7 to 14 g of coffee, with automatic adjustment, according to the programmed services.



AZK V10



AZK V20



AZK V30



3.7.- Installing personalised side panels

VITRO X1 can be personalised by installing personalised side panels.

To replace the panels installed on the machine, proceed as follows:

1. Remove the rear cover by removing its screws
2. Release the three rear anchoring elements of the panel
3. Open the door and remove the front tray
4. Access the three front anchoring elements of the panel
5. The side panel can now be removed. Fit the new panel using the same anchoring elements as those used on the rear panel.

Dimensions of the left side panel

(The right panel is symmetrical)

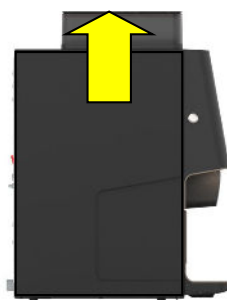
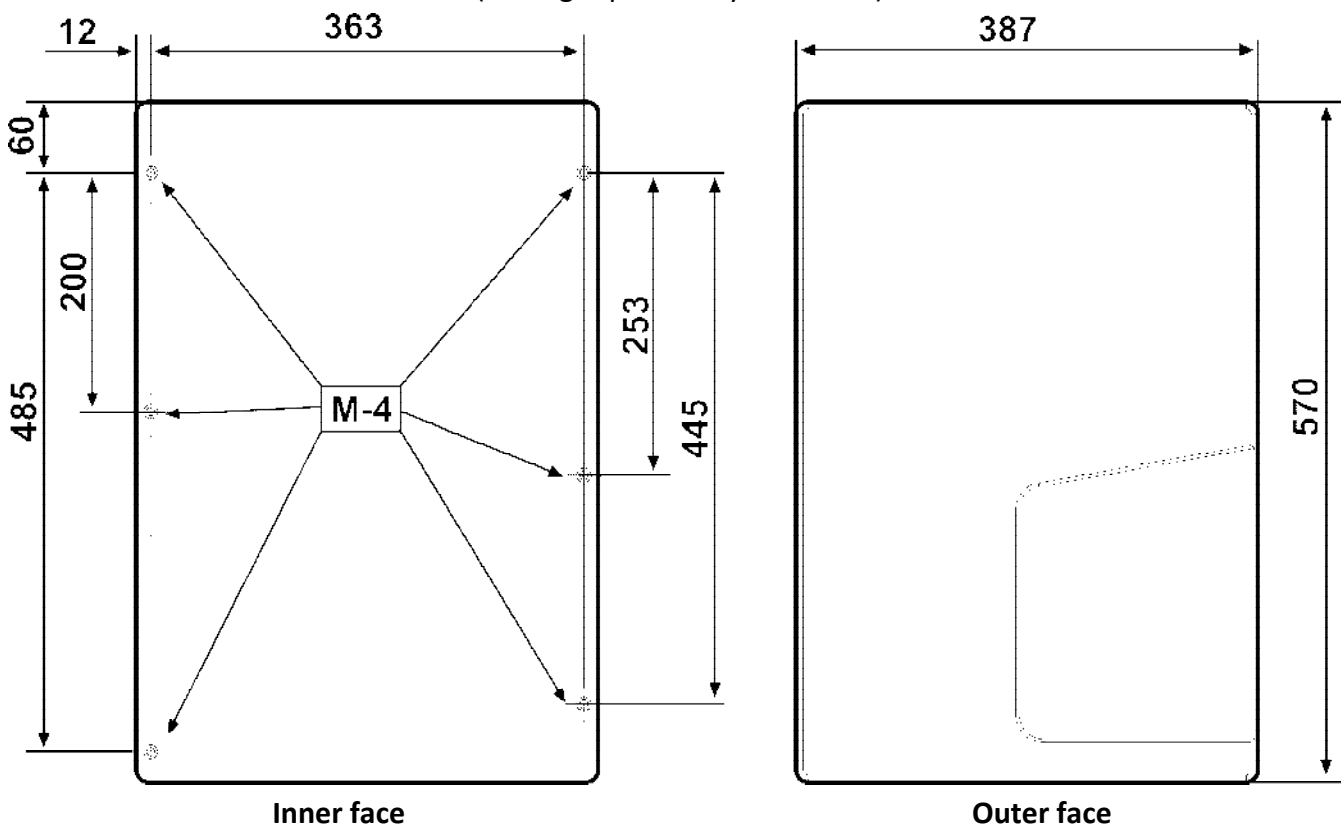

Please contact your authorised AZKOYEN distributor or our Technical Service for more information on customising the machine's side panels.





CHAPTER 4. CONFIGURATION AND PROGRAMMING

4.1.- What is programming?

The machine is cable of performing a series of functions that you can configure. The programming is the actions that you establish in order to determine how the machine will operate in certain functions.

The machine is cable of performing a series of functions that you can configure. The programming is the actions that you establish in order to determine how the machine will operate in certain functions.

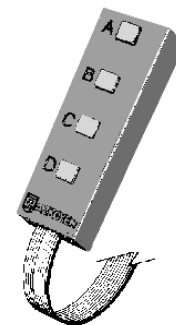

4.2.- Programming control unit

The keys of the programming control unit can be activated in two ways: by simply pressing the key once and by holding the key down for more than 3 seconds.

Operation of the programming control unit in the normal sales mode.

	SINGLE PRESS OF THE KEY	KEY HELD
Key A	One free sale	Enters into the hierarchical programming menu.
Key B	Blender wash	Shows the temp. on the display
Key C	Enters into the basic programming menu	Runs a function directly.
Key D	Allows external programming	Programming of the basic menu functions

The operation of the programming control unit in accessing the functions

Press the C key of the programming keypad. If there have been incidents during service (breakdowns, empty hoppers, etc.), they will appear on-screen. Press the A key again to access the Functions menu (if there have been no incidents, pressing the C key once will suffice). The first function included in the function menus will appear.

	SIMPLE PRESS
Key A	Function goes forward
Key B	Function goes backward
Key C	Exits the programming
Key D	Accesses the function that is displayed at that moment

Operation of the programming control unit in the programming mode.

There are four “editing modes” for communicating with the machine in order to program values in the functions.



Alphanumeric (AB1)		PRESSING THE KEY	
	Key A	The digit being edited goes up one character in the table.	
	Key B	The digit being edited goes down one character in the table.	
	Key C	Erase the digit being edited, and it returns to editing the previous digit.	
	Key D	SINGLE PRESS OF THE KEY	KEY HELD
	The character is validated, and it goes to editing the next digit.	The character being edited is not validated, and it exits from the editing mode.	
Numerical (001)		PRESSING THE KEY	
	Key A	Increases the digit being edited (if it is a sign, it changes)	
	Key B	Decreases the digit being edited (if it is a sign, it changes)	
	Key C	It returns to editing the previous digit (if it is the first number, it edits the sign, and if it is the sign, it exits and validates).	
	Key D	It advances to editing the next digit (if it is the first number, it edits the sign, and if it is the sign, it exits and validates).	
Options List (ABC)		PRESSING THE KEY	
	Key A	The next option on the list is accessed (if it is the last option, it goes to the first).	
	Key B	The previous option on the list is accessed (if it is the first option, it goes to the last).	
	Key C	It goes up one execution level.	

4.3.- Direct access to a function.

By keeping C pressed, the screen displays FUNCTION 000. Choose a function following the numerical editing method.

4.4.- List of functions

The following list details all of the programming functions of the machine in the order in which they are displayed on the machine, thereby indicating the message that will be displayed on the screen, a brief description of the function and a comment about how to operate with the function, if necessary.

The symbol of the editing mode that is used with the function is displayed next to each function. The symbols are the following:

- EXE** Direct execution function.
- AB1** Alphanumeric editing mode.
- 001** Numerical editing mode.
- ABC** Option list editing mode.
- PROP** Editing mode proper to the function



030 TEST MACHINE	ABC	MACHINE TEST BY OPTION LISTS.
	Choose the elements to test.	
110 MONEY/SELECT	EXE	SALES BY SELECTION (CASH)
	Press the desired selection and the screen will display the amount of that selection. Press a new selection in order to continue reading the various amounts.	
120 TOTAL MONEY	EXE	TOTAL AMOUNT OF SALES
	The requested data are displayed on screen.	
201 PRICES PROGR	001	PRICES WITH COINS
	Press the selection and enter the new price. To program another selection, press the selection and repeat the steps. Press C to end.	
204 SINGLE PRICE	001	SINGLE PRICE FOR ALL SELECTIONS
	Program a price. This price is assigned to all selections.	
220 FREE SALE	ABC	FREE SALE
	Select to place the machine in free sale mode for more than one service.	
300 SELECTIONS	ABC	SELECTION-SERVICE ASSOCIATION
	Select the name of the service to associate. Press the desired key where the service is going to be located.	
315 SERV.PROGRAM	PROP	PROP SERVICE PROGRAMMING
	See point 4.5	
420 ADVERT.MESS.	AB1	ADVERTISING MESSAGE
461 TEMPERATURE	001	BOILER TEMPERATURE
	Program the temperature of the boiler water.	
465 AUTONOMY	ABC	STAND ALONE UNIT YES/NO
	Program whether the stand's stand-alone equipment is used or not.	
490 HOPPER NAME	AB1	NAME OF THE HOPPERS
	Program the text assigned to each hopper.	
491 SERV. NAME	AB1	NAME OF THE SERVICES
	Program the text assigned to each service.	
510 DATE/TIME	001	ADJUST TIME AND DATE
	Program the date and then the time.	

4.5.- Service programming.

4.5.1.- What is a service?

A service is the act that the machine performs every time that a customer presses a selection.

When programming a service, each step that the machine needs to take to complete the selected operation must be programmed.



For example, to prepare instant coffee with milk, several actions must be performed:

- 1º - Pour hot water into the cup.
- 2º - Add coffee and stir.
- 3º - Add sugar.
- 4º - Add milk
- 5º - Mix.

It is also a good idea for the actions to overlap each other in order to shorten the service time and to get the optimum mixture.

The service sequence of coffee with milk in the machine could thus be stated as follows:

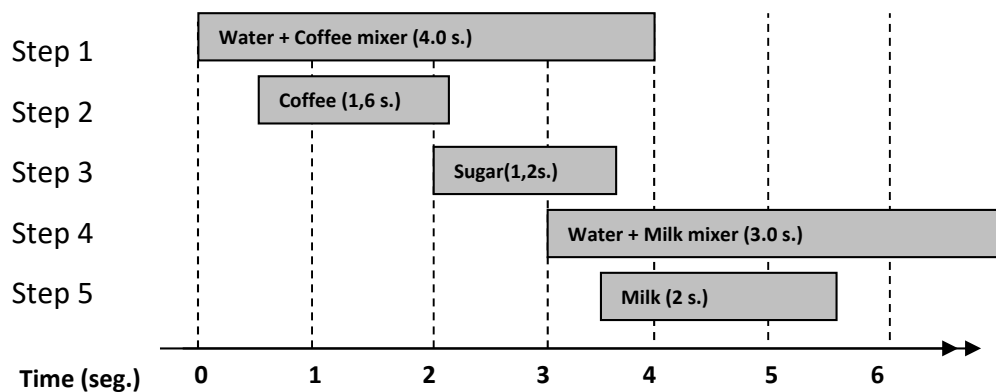

4.5.2.- Function 315 PROG. SERVICE.

The complete configuration of each service can be programmed at function 315.

Select the service to be programmed by pressing the corresponding selection button or using the A and B keys to locate the service.

The following may subsequently be performed:

- **MODIFY** an already-programmed step.
- **ADD** a new step to a service, or
- **DELETE** a step from a service.

Change the values using the programming control keys. The functions of the keys are as follows:

- A or B - Go up or down the "steps"
- C or D - Increase or decrease the amounts (move the bar forward or backward in the figure) The water volumes are measured in seconds.
- To Delete a step or to Create a new one, simply select the desired option using the B key and press D.



If your machine is equipped with a double grinder, you can select the hopper from which the coffee will be dispensed. The hoppers are identified numerically. Hopper 1 is the 1st hopper on the left (looking at the machine from the front).

WARNING!

AFTER CHANGING THE COFFEE DOSAGE, OR AFTER ADJUSTING THE COFFEE GRIND, CHECK TO SEE IF THE SERVICES ARE CORRECT, INCLUDING THE "EXTRA COFFEE" PRESELECTION COMBINATIONS.

DO NOT EXCEED THE DOSAGE OF 8 GRAMS OF COFFEE IN THE SERVICES USING THIS PRESELECTION.





CHAPTER 5. ANOMALY CONTROL AND MAINTENANCE

5.1.- Reset

If the machine is out of service, enter and exit programming by pressing key C on the programming box twice.

5.2.- Possible incidents during a service.

- **If the machine is without of coffee beans** or if there is a problem with serving espresso coffee, the machine allows services of soluble product.
- **Dregs tray is full.** The water inlet is closed and the boiler is turned off until the machine is no longer in FDS (out of service)

5.3.- Service Meters

To facilitate maintenance, the machine is equipped with internal meters that will communicate the amount of services performed and any element that needs to be inspected.

The notification shall consist of an exclamation mark at the bottom left of the screen, similar to that shown when there is an incident. The machine can continue normal operation despite the notification.

The meters are:

- **LITRES X FILTER** -> Indicates the amount of water that has passed through the filter since the last meter reset.
- **ESPRESSO GROUP SERVICES** -> Indicates the number of services performed by the espresso group since the last meter reset.

The meters are active, regardless of whether your machine can support different groups or not. If your machine does not include the Fresh Brew group the meter will logically remain at 0 and therefore the display will never prompt that element.

Enter programming and the display will show the affected element. Refer to the Technical manual to reset the meters.

IF THE MACHINE IS NOT GOING TO BE USED AND WITHOUT SUPERVISION DURING A PERIOD OF TIME, WE RECOMMEND CLOSING THE WATER TAP CONNECTED TO THE MACHINE. MALFUNCTION OF THE INPUT VALVE COULD FLOOD THE MACHINE



5.4.- Disassembly of the coffee bean unit

Use the 030 function to place the group in standby.

Groups AZK V10 & V20. In order to disassemble the complete lower unit, turn the anchor levers of the unit and remove the unit by pulling it outwards.

In order to remove the brewing piston,

1. Remove the fastening pin.
2. Pull up on the piston.
3. In order to completely disassemble the piston, remove the fastening clip.

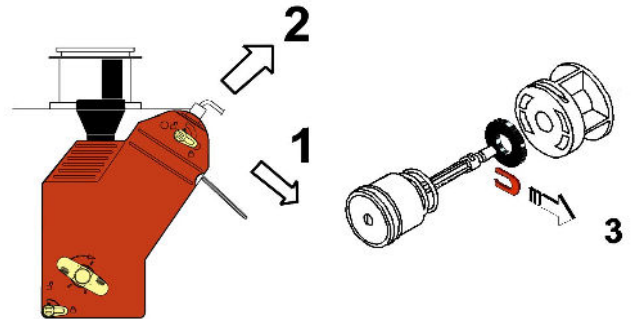

If you wish to **dismantle the entire lower group**, dismantle the group water input hose and then turn the group securing levers and extract the group by pulling it out.

5.5.- Adjustments and regulation

Adjusting the coffee dose in espresso machines with AZK V10 and V20 groups. The group's brewing piston features a washer that can be used to increase or decrease the capacity of the brewing cylinder and adjust the quantity of ground coffee it can contain.

The diagram below indicates the position of the washer to adjust the desired quantity for the AZK V10 and AZK V20 groups.

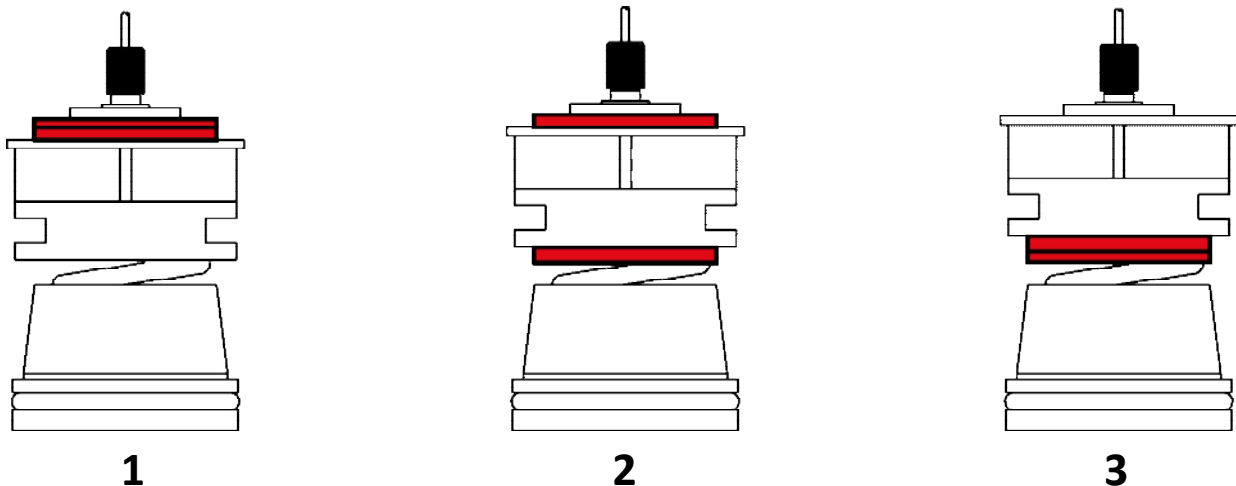



Group	1	2	3
AZK V10	8 gr. - 7gr.	7 gr. - 6 gr	6 gr. - 5gr.
AZK V20	14 gr. - 13 gr.	13 gr. - 11 gr.	11 gr. - 10 gr.

The dose is adjusted at the factory, in group V10, with 6.5 g of ground coffee (100% natural coffee). In groups V20 and V30 it is 14 gr and 7-8 gr respectively.

Machines with the **AZK V30** group feature an automatic adjustment system, according to the values programmed in each service.

Calibrating the COFFEE GRINDER. Use function F030 to calibrate the grinder and ensure that the correct dose is supplied.

Once it has been calibrated, each grinder service will adjust the coffee serving, according to the program using function 315.

For example, every 2.45 seconds of operation of the grinder are equivalent to 7 g. We also recommend adjusting the 22-25 g calibration to 10 seconds.

IMPORTANT NOTE: machines with the AZK V10 and V20 group require the cylinder capacity to be adjusted by changing the washer position, as shown in the diagram above; washers in the upper position for a higher capacity and in the lower position for a smaller capacity. Failure to adjust this properly may cause the group to malfunction and also cause breakdowns.

Calibrating the grinder.

1. Remove the coffee grinder unit, as described in point 5.4.
2. Access the programming menu (see Chap. 4) and select function F030. Press the A and B buttons until the display shows "GRINDER". Next, press the D button.
3. The machine will grind and extract coffee during 10 seconds. Place a container at the grinder outlet to collect the ground coffee.
4. Weigh the extracted product and enter the value using buttons A and B. Validate using button D.

The machine will now indicate the weight of the product in grams.

Adjusting the grind point. The grinder leaves the factory regulated in the optimum grind position. If you want to change the degree of ground of the coffee, proceed as follows:

The grinder adjustment lever is located on top of the Group (**M**). Use it to adjust the degree of ground of the coffee you want. You can move one or two positions of the regulator with the grinder motor running, to avoid locking the wheels with the coffee.



A “good coffee” is one which has been brewed at 9 kg/cm², which is equivalent to a brewing time of between 15 and 20 sec.

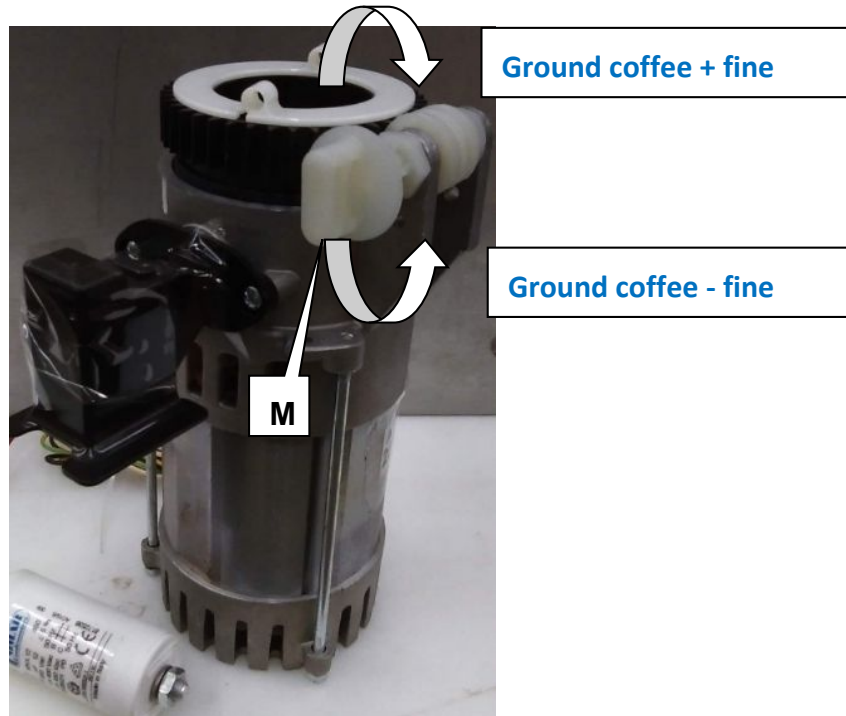

Verify that the dosage is correct whenever an adjustment is made and perform a few coffee services to ensure proper operation.

5.6.- Programming the water temperature under special conditions

The machine is programmed at the factory with an 85°C boiler temperature by default. The water boiling point can be much less than 100°C in some cities, according to their altitude. Malfunction of the hydraulic system of the unit can be caused if the temperature of the machine is modified to higher water boiling temperatures. Examples:

Altitude (over sea level)	Temp. Water boiling	Temp. Max. recommended of the boiler (Function 461)
1500m	95°C	92°C
1800m	94°C	91°C
2100m	93°C	90°C
2400m	92°C	89°C
2700m	91°C	88°C



CHAPTER 6. CLEANING THE MACHINE

MAINTENANCE AND CLEANING TASKS MUST ONLY BE CARRIED OUT BY QUALIFIED STAFF WHO HAVE BEEN TRAINED ON USE AND MAINTENANCE OF THIS MACHINE. ALL OPERATIONS MUST BE CARRIED OUT WITH THE MACHINE DISCONNECTED FROM THE MAINS.

6.1.- Components that require regular cleaning

Depending on the number of services that the machine provides, the machine components must be cleaned more or less regularly:

- Liquid box
- Box used to store the coffee bean remains (in espresso machines)
- Mixers
- Soluble product hoppers
- Suction tube
- Coffee bean assembly
- Front panel of the machine



Liquid box. Simply pull from it, lifting it slightly to extract the box and then extract the tray.

Espresso machines feature a removable box to store the coffee bean remains, which is built into the liquid tray.

When fitting it again, make sure it is inserted correctly and flush to the door.

The box can be fully removed for cleaning. To do so, after removing the tray (and emptying the liquids), press the clips under it and remove the front trim.

The cup holder can also be removed by pressing on the bottom tab while you pull from it.

To fit it again, insert the small short lower tab first and press on the upper tab until the holder is locked into position.

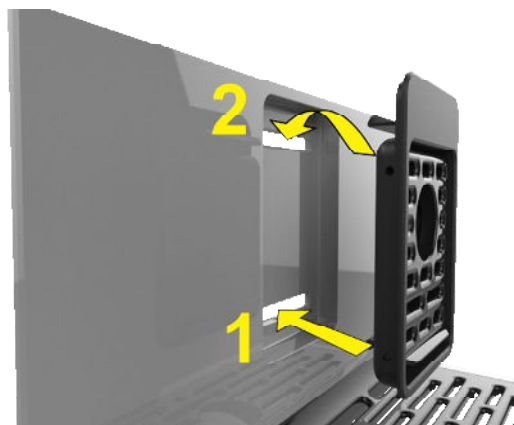
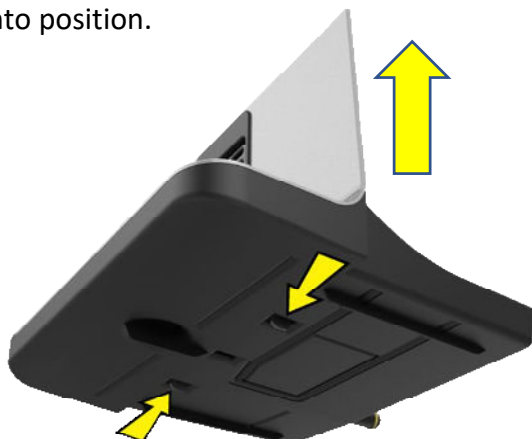



Mixers. Pull from the mixer to extract it and clean it or replace it with a clean mixer.

Remember to fit the outlet elbows of the hoppers facing upwards to avoid the product from falling out and staining the machine when the mixer is removed.

1. Stream hood
2. Mixer chamber
3. Mixing motor
4. Mixer Blade impellor
5. Outlet pipe

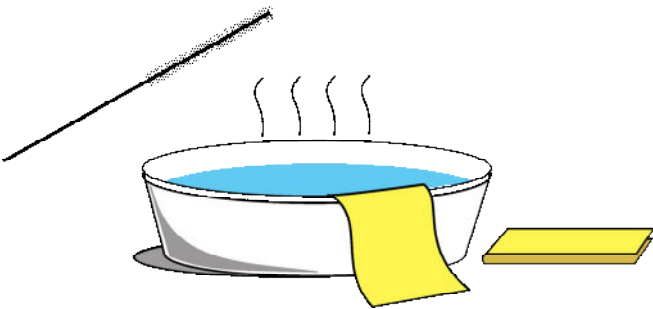
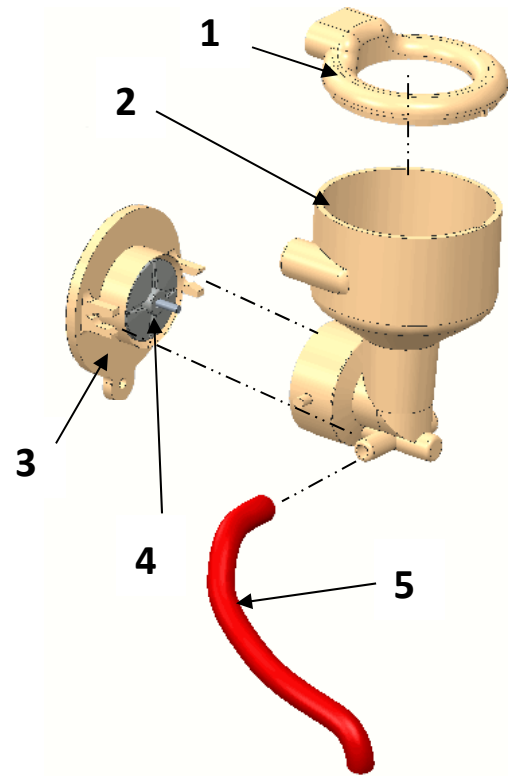

Wash all the components with warm water and remove visible residues using clean cloths and the cleaning brush, which is included in your machine.

Soluble product hoppers. The soluble product hoppers are extracted by pulling from them, from the top of the machine. Remove the upper frame by manually removing the screw holding it from the inside.

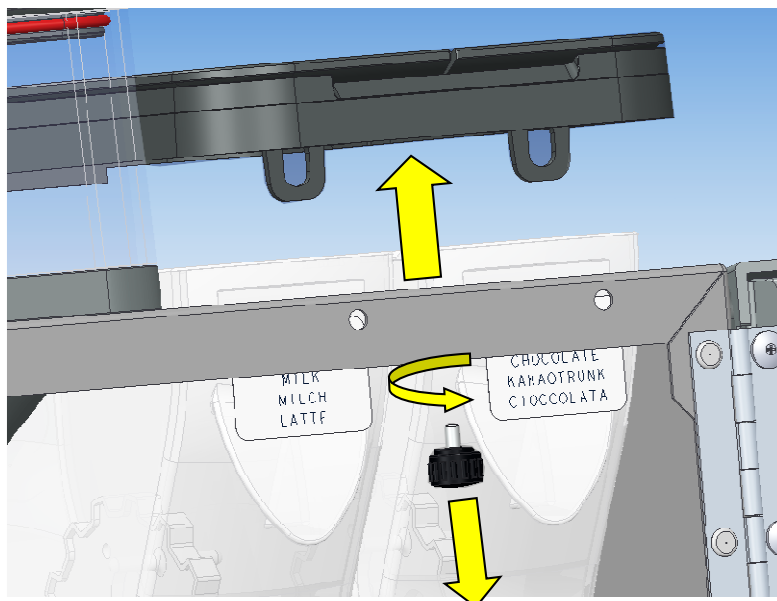



When the frame has been removed, pull from the hopper upwards to remove it. Remember that you must twist the elbow pieces first to prevent liquids from being spilled on the machine.

Also clean the part covered by the frame.

If you wish to clean the machine more thoroughly, after removing the hoppers, you can remove the suction intake, on which the hoppers are supported (Fig. 1).



When the machine has been cleaned, insert the hoppers again, ensuring they fit properly, and mount the frame again, holding it from the inside with a bolt and fitting the outlet elbow pieces correctly.

6.2.- Regular cleaning of the machine and maintenance operations

The following table details the recommended cleaning and frequency:

<p>Once a week or every 700 services</p>	<ul style="list-style-type: none"> • Clean the mixer (Press F) • Clean the surface of the mixer area • Drain the spill tray • Clean the services compartment • Clean the front of the machine after all the above operations have been done
<p>Once a month or every 5,000 services</p>	<ul style="list-style-type: none"> • Remove the mixer blades. Wash with hot water • Remove the product hoppers and clean the base of the area • Clean intake manifolds
<p>Once a year or every 25,000 services</p>	<ul style="list-style-type: none"> • Perform all of the above. • Change the coffee filter of the group (see 3.7). • Wash the filter using the Cleaning Cycle (see 6.3), or retreat to thoroughly clean with detergent
<p>Once every 4 years or every 20,000 services</p>	<ul style="list-style-type: none"> • Check the wheels of the grinder and replace if necessary.

6.3.- Cleaning cycle for the group brewing chamber

For hygiene reasons, this process should be performed at least once every three months in order to eliminate coffee particles from the brewing chamber.

Use special detergent tablets for super-automatic coffee machines. There are tablets weighing 2 to 3 g available on the market.



Before you start, remove the liquid tray from the machine. Empty it of solid and liquid waste. Put it back into position on the machine.

You also need a cleaning tablet ready for use.

AZKOYEN CAN SUPPLY YOU WITH A KIT OF CERTIFIED TABLETS. REQUEST REFERENCE 09725700 FROM YOUR TECHNICAL SERVICE.

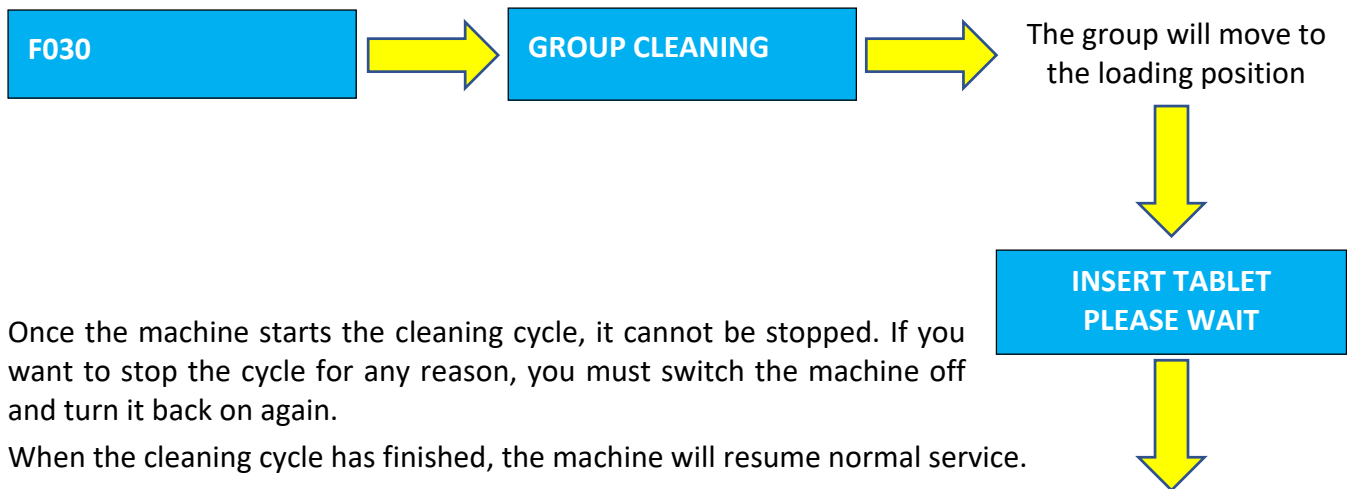

Once the machine starts the cleaning cycle, it cannot be stopped. If you want to stop the cycle for any reason, you must switch the machine off and turn it back on again.

When the cleaning cycle has finished, the machine will resume normal service.

For correct cleaning, you should remove the brewing piston and clean the upper filter with cleaning paper or a brush to eliminate any particles which may remain on the filter. To dismantle the piston, follow the instructions in 3.7.

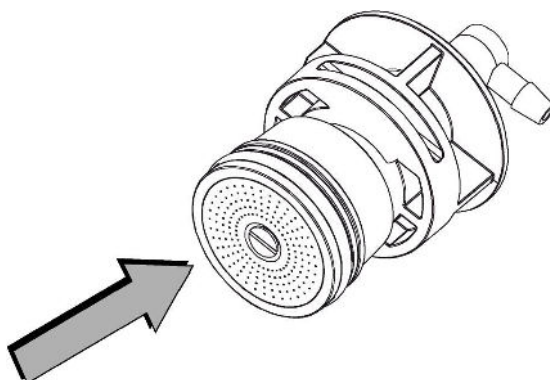



6.4.- Exterior cleaning



Do not use spray! Use warm water (between 20°C and 40°C) and one of the following products: Washing-up liquid, neutral shampoo, alcohol-free window cleaner.

Rinse with a 2% vinegar (acetic acid) solution and dry with a soft cloth or duster.

If there are stubborn stains (grease, beverages, etc.), use a solution of water and sanitary alcohol (96° Ethanol) at 1 % concentration.



Anexe 1. THE TREATMENT, COLLECTION, RECYCLING AND DISPOSAL OF THIS DEVICE

DIRECTIVE 2002/96/CE ON THE TREATMENT, COLLECTION, RECYCLING AND DISPOSAL OF ELECTRIC AND ELECTRONIC DEVICES AND THEIR COMPONENTS

INFORMATION

1. For countries in the european union (EU)

The disposal of electric and electronic devices as solid urban waste is strictly prohibited: it must be collected separately. The dumping of these devices at unequipped and unauthorized places may have hazardous effects on health and the environment. Offenders will be subjected to the penalties and measures laid down by the law.

To dispose of our devices correctly

- a) Contact the Local Authorities, who will give you the practical information you need and the instructions for handling the
- b) waste correctly, for example: location and times of the waste collection centres, etc.
- c) When you purchase a new device of ours, give a used device similar to the one purchased to our dealer for disposal.



The crossed dustbin symbol on the device means that:

- When it to be disposed of, the device is to be taken to the equipped waste collection centres and is to be handled separately from urban waste;
- The producer guarantees the activation of the treatment, collection, recycling and disposal procedures in accordance with Directive 2002/96/CE (and subsequent amendments).

2. For other countries (not in the EU)

The treatment, collection, recycling and disposal of electric and electronic devices will be carried out in accordance with the laws in force in the country in question.